

## Unit 9 Triangles Review Guide

**9.1 Simplifying Radicals** – You must know how to simplify radicals, in all different forms. If a question says to “give an exact answer”, that means your answer should be a radical or an integer. No decimals.

1)  $\sqrt{80}$

2)  $\sqrt{75}$

3)  $3\sqrt{72}$

4)  $5\sqrt{108}$

5)  $\frac{\sqrt{27}}{\sqrt{9}}$

6)  $\frac{\sqrt{25}}{\sqrt{5}}$

7)  $(3\sqrt{7})^2$

8)  $(5\sqrt{2})^2$

9)  $(5\sqrt{2})(2\sqrt{8})$

10)  $4(5\sqrt{7})$

11)  $\sqrt{8} + 5\sqrt{8}$

12)  $2\sqrt{32} + 11\sqrt{2}$

**9.2 The Pythagorean Theorem** – If you are given two sides of a right triangle, you can immediately find the third side by using  $a^2 + b^2 = c^2$ . Remember that a and b represent the legs, and c represents the hypotenuse (the side opposite the  $90^\circ$  angle). Make sure to appropriately use parenthesis when applying the theorem. For example, if  $a = 3\sqrt{2}$ , then  $a^2 = (3\sqrt{2})^2 = 18$ . Lastly, here are some Pythagorean Triples you should know:

3, 4, 5

5, 12, 13

7, 24, 25

8, 15, 17

Find the missing side length.

13)

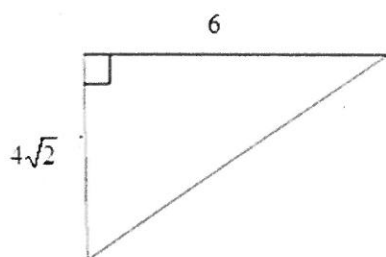

14)

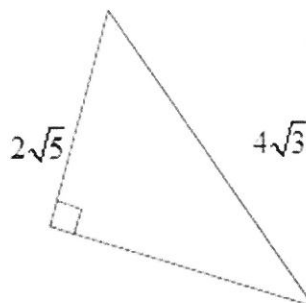

**Pythagorean Theorem Converse** – If  $a^2 + b^2 = c^2$ , then the triangle is right. If  $a^2 + b^2 < c^2$ , then the triangle is obtuse. If  $a^2 + b^2 > c^2$ , then the triangle is acute. Classify each triangle by its angles.

15)  $3\sqrt{3}$  ft, 6 ft, 3ft

16) 5, 5, 7

17)  $2\sqrt{3}$ ,  $3\sqrt{5}$ , 6

**Distance**  $D = \sqrt{(x_2 - x_1)^2 + (y_2 - y_1)^2}$ .

Plot both points, find the length of each leg by finding the difference in x's and y's, then use the Pythagorean Theorem to find the hypotenuse (distance). Find the distance between the points.

18) (2, -13) (-3, 1)

19) (28, -41) (33, -53)

20) (34, 2) (44, -3)

**9.3 Special Right Triangles** (short to long-multiply/long to short-divide)

45-45-90-The ratio between each leg and the hypotenuse is  $\sqrt{2}$ .

30-60-90-The ratio between the short and long leg is  $\sqrt{3}$ , short and hypotenuse is 2.

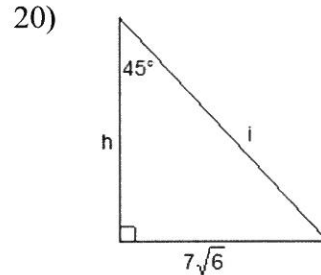
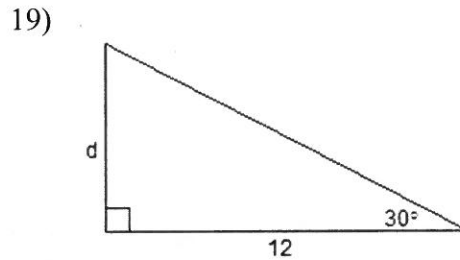
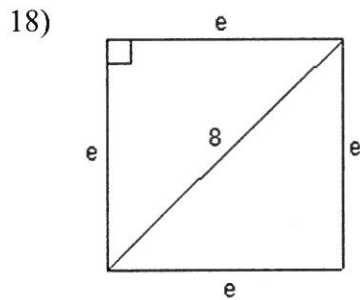

**9.4 Similar Right Triangles**

Solve for the variable.

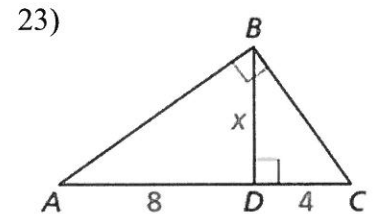
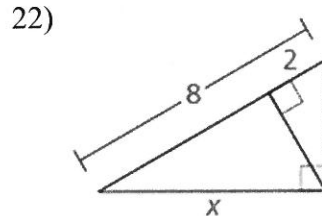
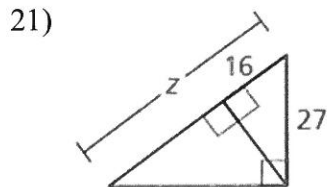

### 9.5-9.6 Trigonometry

$S=O/H$ ,  $C=A/H$ ,  $T=O/A$

$\text{Sin}(\text{Angle}) = \text{Ratio}$ ,  $\text{Sin}^{-1}(\text{Ratio}) = \text{Angle}$ . You use  $\text{sin}$ ,  $\text{cos}$  and  $\text{tan}$  when you are looking for missing sides. You use  $\text{sin}^{-1}$ ,  $\text{cos}^{-1}$  and  $\text{tan}^{-1}$  when you are looking for missing angles.

24)

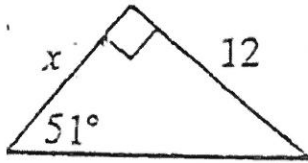

25)

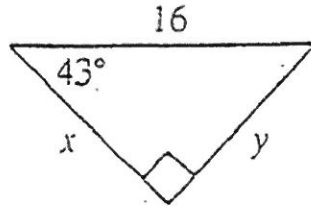

26)

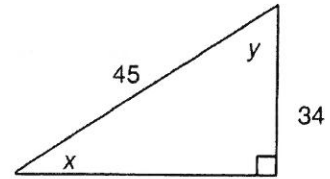

27) The angle of elevation from a ship to the top of a 42-meter lighthouse on the shore measures 33 degrees. How far is the ship from the lighthouse?

28) A building that is 40 feet high casts a shadow that is 22 feet long. What is the angle of elevation of the sun?

### 9.7 Solving Right Triangles

Solve for all of the missing angles and side lengths of the given triangles.

29.

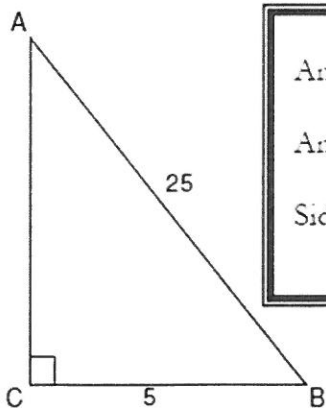

<p>Angle A =</p> <p>Angle B =</p> <p>Side b =</p>
---

30.

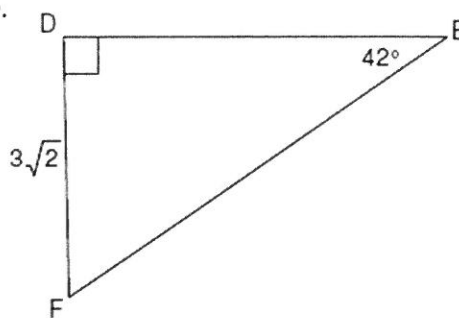

<p>Angle F =</p> <p>Side f =</p> <p>Side d =</p>
--

31.

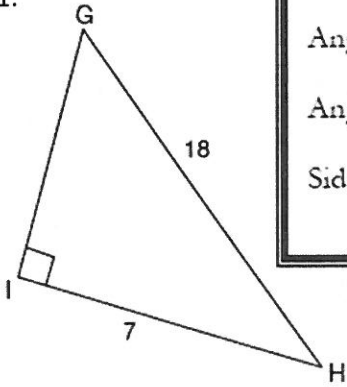

Angle G =  
 Angle H =  
 Side h =

32.

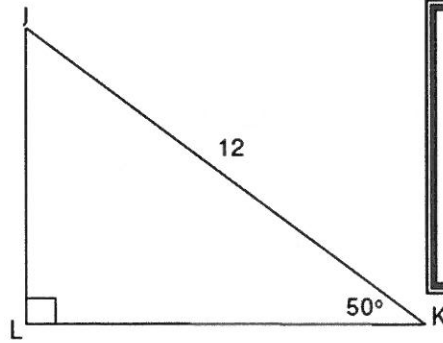

Angle J =  
 Side j =  
 Side k =

33.

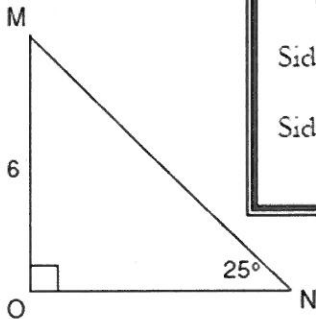

Angle M =  
 Side o =  
 Side m =

34.

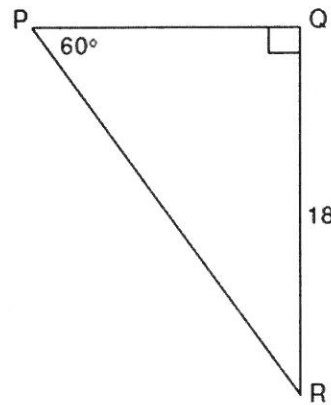

Angle R =  
 Side r =  
 Side q =

### 9.7 Law of Sines/Law of Cosines

$$\frac{\sin(\text{Given Angle})}{(\text{Given opposite side})} = \frac{\sin(\text{Angle you are looking for})}{(\text{Given opposite side})} \text{ or } \frac{\sin(\text{Given Angle})}{(\text{Given opposite side})} = \frac{\sin(\text{Given Angle})}{(\text{Side you need})}$$

Law of Sines (AAS or ASA):  $\frac{\sin A}{a} = \frac{\sin B}{b} = \frac{\sin C}{c}$ . (Must use  $\sin^{-1}$  if looking for an angle).

Law of Cosines:  $c^2 = a^2 + b^2 - 2ab\cos C$  given SAS and  $C = \cos^{-1}\left(\frac{c^2 - a^2 - b^2}{-2ab}\right)$  given SSS.

Solve each triangle for all the missing sides and angles.

35)



$$\begin{aligned} \angle Z &= 74^\circ \\ \overline{UC} &= 98.3 \\ \overline{ZC} &= 71.7 \end{aligned}$$

36)



$$\begin{aligned} \angle J &= 82^\circ \\ \angle Y &= 39^\circ \\ \overline{YN} &= 14.9 \end{aligned}$$

37)

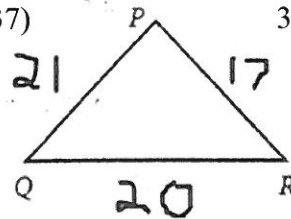

38)

